

DISHWASHERS

FREESTANDING
600

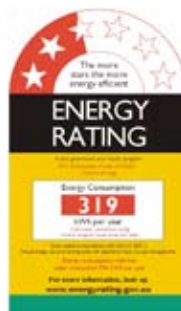

- Colour:** Stainless Steel
- Model:** ADF6SE1
- Dimensions:** 850mm (H) x 600mm (W) x 580mm (D)
- Features:**
- Freestanding
 - Semi electronic controls
 - International 12 place settings
 - 5 wash programmes
 - 15.7 litre water consumption
 - 4 wash temperatures
 - ½ load option
 - Adjustable top basket
 - Tall glass supports (top basket)
 - Drop down supports (bottom basket)
 - 3 section cutlery basket
 - Concealed heating element
 - Overflow protection

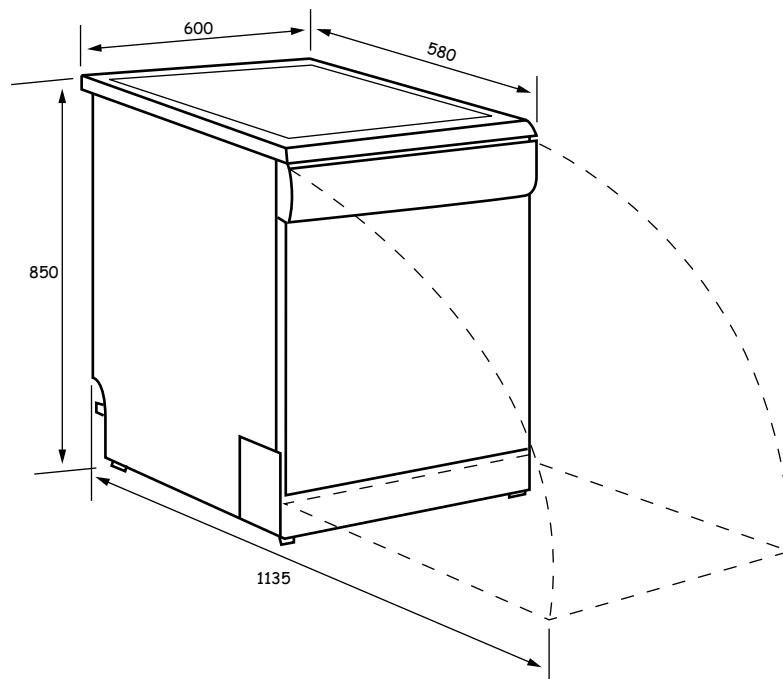

DISHWASHERS**FREESTANDING
600**

All ARC Appliances have a complete 2-Year Warranty on parts and labour. Our Toll Free Customer Service Number 1800 805 300 provides helpful advice and ready access to a nationwide service team.

**EXTENDED WARRANTY**

All ARC electric or gas appliances for your kitchen are now available with an OPTIONAL full 5 year Parts and Labour Warranty. Visit www.arcappliances.com.au or call our Toll Free Customer Service Number 1800 805 300 for details.