

# COFFEE MACHINES

## INTEGRATED COFFEE MACHINE



<b>Colour:</b>	Stainless Steel
<b>Model:</b>	IKI6SE1
<b>Dimensions:</b>	450mm (H) x 600mm (W) x 252mm (D) + 20mm fascia
<b>Total Kilowatts:</b>	1200W
<b>Power Requirements</b>	240V 10 amps
<b>Coffee Thermostat:</b>	95° C - 15 amp rated, 250V - T 210°
<b>Steam Thermostat:</b>	125° C - 15 amp rated, 250V - T 210°
<b>Pump Specification:</b>	230V, 48V, 15 bars
<b>Coffee Grinder Capacity:</b>	380ml
<b>Water Container Capacity:</b>	4.6 litres
<b>Max. Flow Rate:</b>	600ml / minute
<b>Electrical Connection:</b>	The appliance is supplied with a flexible earthed supply lead fitted with a three pin plug.
<b>Method of Installation:</b>	Built into cabinet - extends out on heavy duty progression runners for access to water and coffee bean storage.

**COFFEE  
MACHINES**

INTEGRATED  
COFFEE  
MACHINE

**COFFEE MACHINE  
DIMENSIONS**

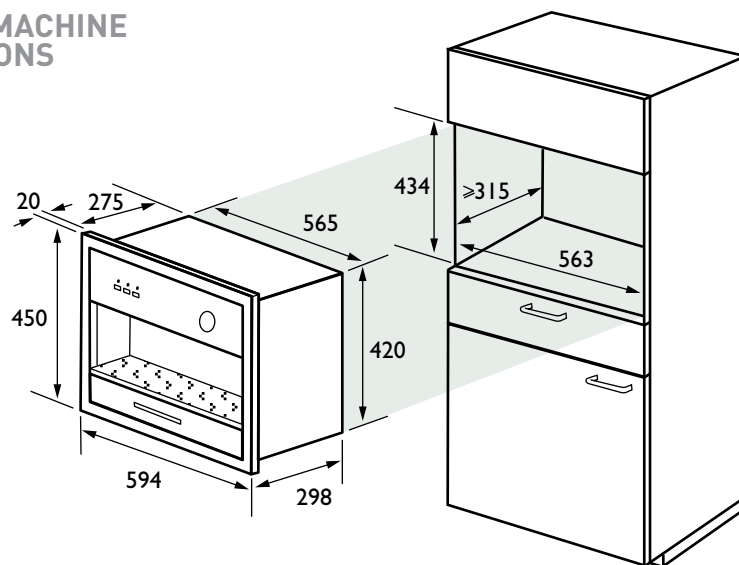

All ARC Appliances have a complete 2-Year Warranty on parts and labour. Our Toll Free Customer Service Number 1800 805 300 provides helpful advice and ready access to a nationwide service team.



**EXTENDED WARRANTY**

All ARC electric or gas appliances for your kitchen are now available with an OPTIONAL full 5 year Parts and Labour Warranty. Visit [www.arcappliances.com.au](http://www.arcappliances.com.au) or call our Toll Free Customer Service Number 1800 805 300 for details.